

ATEX detectors

Our hazardous area solution

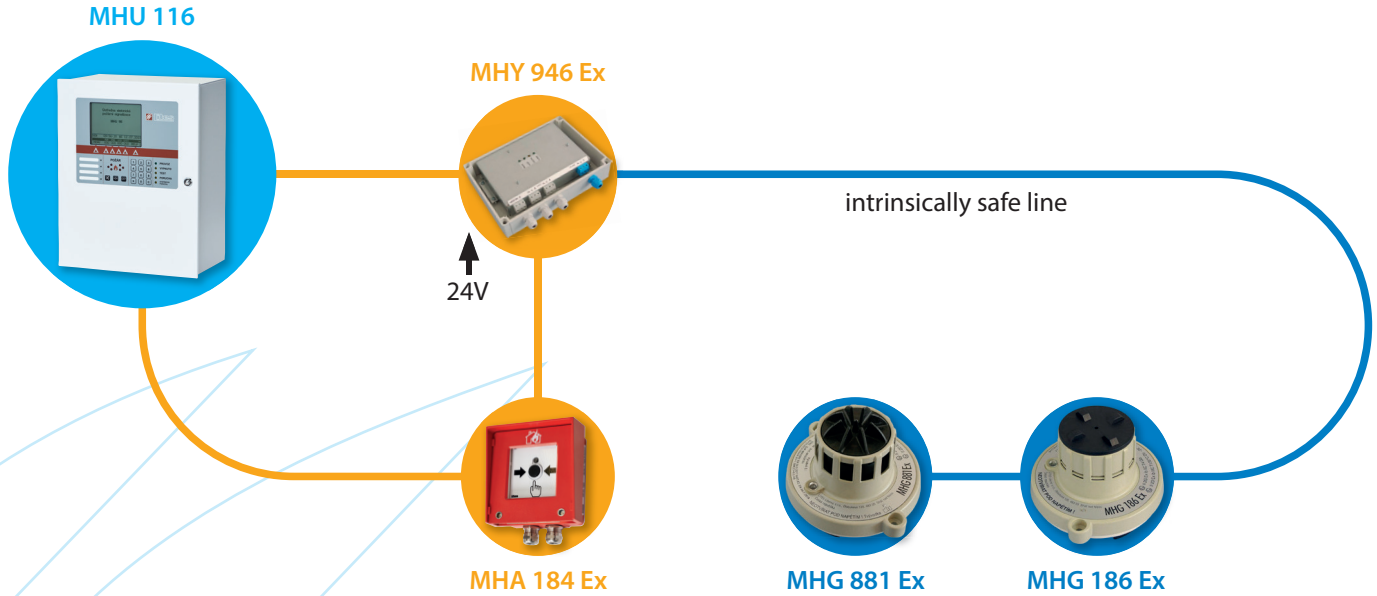

MHG 186 Ex IONIZATION DETECTOR



- Detector responding to combustion products - visible and invisible smoke particles (aerosols)
- Increased IP65
- Ex II 2G Ex ib IIC T4 Gb
- Ex II 2D Ex ib IIIC T135 °C Db
- Mounting base MHY 741 Ex

MHG 881 Ex MULTISENSOR DETECTOR



- Combines two principles - optical and heat
- Increased IP65
- Ex II 2G Ex ib IIC T4 Gb
- Ex II 2D Ex ib IIIC T135 °C Db
- Mounting base MHY 741 Ex

MHY 946 Ex SEPARATION UNIT



- Connection up to 32 intrinsically safe detectors
- Blue intrinsically safe cable
- external power supply 22-30Vdc
- {Ex} II (2)G [Ex ib Gb] IIC
- {Ex} II (2)D [Ex ib Db] IIIC

MHA 184 Ex MANUAL CALL POINT



- manual pushbutton detector
- Increased IP65
- {Ex} II 3G Ex ec ic IIC T5 Gc
- {Ex} II 2D Ex tb IIIC T 80 °C Db